

Optimizing Preparative LC/MS Configurations and Methods for Parallel Synthesis Purification

Karl F. Blom, Richard Sparks, James Doughty, J. Gerard Everlof, Tasir Haque, and Andrew P. Combs

J. Comb. Chem., **2003**, 5 (5), 670-683 • DOI: 10.1021/cc020086n • Publication Date (Web): 29 July 2003

Downloaded from <http://pubs.acs.org> on March 20, 2009

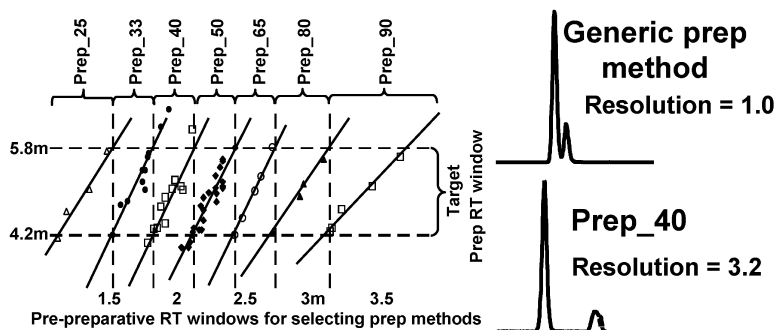

More About This Article

Additional resources and features associated with this article are available within the HTML version:

- Supporting Information
- Links to the 1 articles that cite this article, as of the time of this article download
- Access to high resolution figures
- Links to articles and content related to this article
- Copyright permission to reproduce figures and/or text from this article

[View the Full Text HTML](#)

Optimizing Preparative LC/MS Configurations and Methods for Parallel Synthesis Purification

Karl F. Blom,^{*,†} Richard Sparks,[†] James Doughty,[‡] J. Gerard Everlof,[§]
Tasir Haque,[⊥] and Andrew P. Combs[†]

*Bristol-Myers Squibb Company, New Leads Chemistry, P.O. Box 4000,
Lawrenceville, New Jersey, 08543-4000, and Bristol-Myers Squibb Company,
PRI Discovery Chemistry, P.O. Box 4000, Lawrenceville, New Jersey, 08543-4000*

Received September 25, 2002

Preparative LC/MS is widely employed to address the high-throughput purification demands of parallel synthesis. However, conflicting chromatography requirements and the complexities of applying MS-directed fractionation can limit its effectiveness in high-throughput parallel synthesis schemes. We report here an at-column dilution small-scale preparative LC configuration which satisfies the mass loading (>20 mg) and small fraction volume (<1.5 mL) requirements of discovery parallel synthesis schemes employing plate mapping. We also present a protocol for compound-specific optimization of the preparative gradient LC method and MS threshold for fractionation from a “prepreparative” LC/MS analysis of the crude material. We will demonstrate significantly improved preparative separations (relative to “universal” prep LC methods) and the selection of reliable and effective fraction threshold methods for diverse libraries. The methods and configurations are simple to implement and are equally suited for “open access” and “expert” applications of preparative LC/MS purification.

Introduction

Parallel and robotic synthesis techniques have transformed the drug discovery process, greatly increasing the rate at which new chemical space can be explored for potential leads and the expediting the investigation of the structure–activity relationship (SAR) of lead series. In both of these processes, it is becoming clear that compound purity is critical, affecting the validity and accuracy of the biological screens and, therefore, the validity and rapidity of the research.^{1,2} Preparative liquid chromatography–mass spectrometry (prep LC/MS) is widely recognized as an efficient and effective means for meeting the high-throughput purification needs of parallel synthesis programs.^{3–5} The specificity of mass-directed fractionation can reduce the number of fractions collected (often to a single fraction corresponding to the desired product) and improve the purity of the collected fraction (by effecting a “center cut” on the desired product when partially unresolved components are present). In practice, however, the effectiveness of prep LC/MS is often diminished by the inherent complexities of mass spectrometric detection and the challenging purification requirements of some parallel synthesis strategies. In this report, we address the three factors which most significantly limited the utility of prep LC/MS purification within our parallel synthesis program:

(1) the loading capacity/flow rate requirements of conventional LC methods limit the practical utility of plate mapping protocols; (2) the resolution of fast generic gradient LC methods is often inadequate to achieve purity requirements, and tools for high-throughput “optimization” of preparative LC separations are not available; and (3) practical and reliable methods for determining appropriate MS fraction collection thresholds are not available.

A principal benefit of mass directed fractionation is the ability to plate map fractions,⁵ thereby simplifying subsequent robotic manipulation. However, conventional prep LC/MS configurations impose restrictions on the application of this technique. Purification yield requirements are program-dependent, but typical pharmaceutical discovery screening and archiving scenarios often require 10–20 mg (or more) of purified product. Conventional LC configurations may require the use of columns up to 20 mm in diameter and flow rates up to 25 mL/min for the purification of 20 mg of material. Assuming a peak/fraction width of ~20 s, 20 mg of product will typically be purified into a volume of more than 8 mL. Consequently, prep LC/MS plate mapping protocols generally utilize large -volume collection formats (e.g., 4-mL 48-well plates or larger volume custom plate formats), or limit the quantity of material to be purified (usually <20 mmol or 10 mg), or require collecting into multiple wells. We report here the use of the two-pump at-column dilution (ACD) LC loading configuration^{6–9} with small-scale chromatography (flow rate = 4 mL/min) to purify quantities of material >20 mg. We will demonstrate the

[†] Current address: Incyte Corporation, Discovery Chemistry, DuPont Experimental Station, Building 336, Rt 141 and Henry Clay Rd., Wilmington, DE 19880. Center.

[‡] Current address: 243 Pilot Town Rd., Conowingo, MD.

[§] Bristol-Myers Squibb Company, New Leads Chemistry.

[⊥] Bristol-Myers Squibb Company, PRI Discovery Chemistry.

collection of >20 mg of compound into fraction volumes of <1.5 mL. With this configuration, typical discover scale reaction mixtures can be conveniently purified directly into 2-mL 96-well plate formats. Additional benefits of the ACD configuration include greatly reduced solvent consumption, a similarly reduction in waste production, faster dry-down time for purified products (a result of reduced fraction volume), use of less expensive columns, and fewer restrictions on sample diluent (strong solvents such as DMSO may be used) and injection volume.⁶

The obstacles most frequently encountered by prep LC/MS users (particularly in open access applications) are (1) inability to attain adequate chromatographic separation (resulting in impure product) and (2) failure to employ an appropriate MS fraction collection threshold (with the result of either losing the sample because the threshold is set too high or collecting indiscriminately because the threshold is set too low). Since practical and reliable LC and MS method development tools are not generally available to the prep LC/MS user, it is a common practice to employ generic or "universal" LC and MS fraction methods for all purifications. The shortcomings of this strategy are obvious. A well-designed universal LC gradient method will elute the product and most likely yield some chromatographic separation but cannot provide the resolution (and hence, the product purity) of a method employing a focused gradient appropriate for the compound of interest. Mass spectrometric responses for members of discovery libraries frequently vary by more than an order of magnitude (as a result of disparity in MS sensitivity/response factor and chemistry yield). Libraries containing greater structural diversity or employing less well characterized chemistry can easily exhibit MS responses differing by as much as two orders of magnitude. Consequently, a universal fraction collection threshold will often fail to collect those members with low MS sensitivity or provide inadequate fraction specificity for members with high MS sensitivity.

Conventional approaches for optimizing and scaling up preparative LC methods¹⁰ can be cumbersome to apply in high-throughput situations. Computational approaches to predicting and optimizing chromatography, such as correlating calculated distribution coefficients (cLogD) to chromatographic retention, appear promising but cannot yet provide the needed chromatographic resolution and reliability. Protocols for optimizing prep LC gradients directly from analytical scale LC retention data have been reported,^{11,12} but applications employing this strategy are not generally available to prep LC/MS users. Analogous procedures to establish the MS threshold for preparative fraction collection from an analytical scale MS analysis have not been reported. This is at least in part because the disparity between typical preparative and analytical ionization conditions (e.g., isocratic methanol vs gradient acetonitrile/water source flow) and source loading (micrograms vs nanograms) render the relationship between preparative and analytical MS responses very complex and ultimately unreliable. We present here a protocol for the compound-specific optimization of both the preparative LC gradient method and the MS threshold for fractionation directly from a prepreparative LC/MS analysis

of the crude material. The prepreparative LC/MS configuration couples fast "analytical scale" liquid chromatography directly to the preparative splitter/makeup/mass spectrometer configuration. This hybrid configuration produces a direct and reliable correlation between the prepreparative MS response and the optimal or "ideal" prep MS threshold for fractionation.

In this protocol, the prepreparative LC retention time is used to select the most appropriate prep LC method from a small, comprehensive ensemble of "focused" gradient methods. Similarly, the "ideal" preparative MS threshold for fractionation is estimated directly from the prepreparative MS response and used to select the most appropriate MS fraction method from a small, comprehensive ensemble of MS fraction methods. Software has been created that interrogates the prepreparative LC/MS data, selects the most appropriate preparative LC and MS fraction methods, and automatically builds the parameter table for the preparative LC/MS purification. With this prepreparative analysis and method selection protocol, we will demonstrate significantly improved chromatographic separations (vs generic prep LC methods) and reliable selection of appropriate fraction methods for diverse libraries. The time, effort, and product expended in the compound-specific method optimization process are modest compared to the advantages realized.

A major consideration in designing these systems was simplicity of implementation; that is, the configurations and protocols must be accomplished without major alteration of the vendor-provided hardware or software. Modifying a conventional LC employing high pressure mixing for at column dilution operation requires little or no additional hardware and only simple modification of the plumbing. Similarly, the prepreparative LC/MS configuration is created by the simple addition of an appropriately sized LC column and column switching hardware. The method selection software operates separate from the vendor instrument control software; no modification of the vendor software is necessary. Although we chose to create a relatively sophisticated graphical user interface for the application of the method optimization protocols, these protocols can be effectively accomplished with a simple spreadsheet. The configurations and protocols described here are suitable for both "open access" and "expert" applications of preparative LC/MS.

Experimental Section

The at-column dilution LC/MS configuration with preparative and prepreparative capability is shown schematically in Figure 1. The high-pressure LC pumps are Gilson 306 modules fitted with 5.SC pump heads (maximum flow rate of 5 mL/m) with an 805 manometric module connected to the output of the aqueous pump. The injector/collector is a Gilson 215 liquid handler with a 0.4-mm-i.d. needle, Gilson part no. 27067377 (using larger-i.d. needles causes peak broadening at the fraction collector, resulting in lowered recovery). The preparative/analytical splitter is an LCPackings ACM-1-10 (1:1000 split, flow rate range 1–10 mL/m); the makeup pump is a Waters Reagent Manager, and the detector splitter is a 0.010-in.-i.d. PEEK tee with tubing diameters and lengths adjusted to provide an ~1:20 split (5%

Table 1.

Prepreparative LC Method			Universal Preparative LC Method		
time ^a	% acetonitrile	flow rate ^b	time ^a	% acetonitrile	flow rate ^b
0	10	2	0	10	2
0.1	10	4	0.1	10	4
0.5	10	4	2.0	10	4
3.5	100	4	7.0	100	4
4.5	100	4	8.0	100	4
4.6	10	4	8.1	10	4

Focused Preparative LC Methods								
time ^a	flow rate ^b	% AcN						
		Prep_25	Prep_33	Prep_40	Prep_50	Prep_65	Prep_80	Prep_90
0	2	10	11	15	20	26	33	38
0.1	4	10	11	15	20	26	33	38
2.0	4	10	11	15	20	26	33	38
2.1	4	15	23	30	40	52	65	78
7.0	4	35	43	50	60	66	78	90
7.1	4	100	100	100	100	100	100	100
8.0	4	100	100	100	100	100	100	100
8.1	4	10	10	10	10	10	10	10

^a Time in minutes. ^b Flow rate in mL/m.

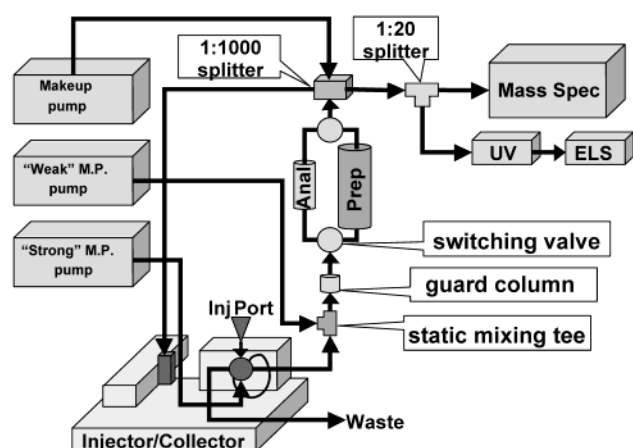

Figure 1. Schematic representation of preparative/prepreparative LC/MS configuration with at-column dilution sample loading.

flow to MS). The sample is loaded onto the LC column from the organic solvent stream. The solvent mixing (at column dilution) is accomplished with a static mixing tee (Upchurch, part no. U-466). The mode/column switching valves are two-position LabPRO modules, EV700-100, operated with two-line BCD control. All the tubing between the high-pressure pumps and the injector valve and ACD mixing tee is 0.020-in.-i.d. stainless steel. (The volume of the system prior to the injector valve and ACD mixing tee is irrelevant to the chromatographic performance; thus, relatively large bore tubing is utilized to minimize back pressure.) All tubing after the injector and ACD mixing tee is 0.010-in.-i.d., either stainless steel tubing or PEEK tubing, as appropriate. The mass spectrometer is a Waters ZQ2000, the UV detector is a Gilson 155, and the ELSD is a Sedex 75C. The mass spectrometer, LC, and mass-directed fraction collection are controlled via Micromass Masslynx version 3.5 with Fractionlynx.

The preparative LC/MS mode employs a 7.8×100 -mm Symmetry C-18, 5- μ m particle size column (Waters, 186000209); the prepreparative column is a 4.6×50 -mm Symmetry C-18, 5- μ m particle size (Waters, 186000207). In both modes, the guard column is a 4.6×12.5 -mm

ZORBAX SB-C18, 5- μ m particle size (Agilent, 820950-920). The preparative and prepreparative LC methods are summarized in Table 1. The organic phase is acetonitrile with 0.1% trifluoroacetic acid (TFA); the aqueous phase also contains 0.1% TFA. The set flow rate for all methods was 4 mL/min; the actual measured flow rate (measured postcolumn at several mobile phase compositions) was 3.6 mL/m. The makeup flow was 1 mL/min of methanol.

At 3.6 mL/min and 10% acetonitrile composition (the loading conditions for the universal prep LC method), the flow carrying sample from the sample loop to the column is 0.36 mL/m. At this flow rate, the ACD loading of the sample onto the column takes ~ 2.8 min/mL of sample.⁶ The 2-min hold for sample loading at the beginning of the universal LC method is sufficient to load ~ 0.7 mL of sample. The sample loading volume for all of the prep LC/MS purifications reported here was 0.5 mL. The sample volumes used for the systematic loading studies with reference standards varied from 25 μ L to 1.0 mL. (Note: when loading sample volumes > 0.7 mL with the universal prep method, the loading phase was extended to 3 min to allow complete loading of the sample onto the column prior to starting the gradient.) The more hydrophobic focused gradient prep methods load the sample at higher organic compositions. The method designated Prep_65, for example, loads the sample at 26% acetonitrile, and the loading time for 0.5 mL of sample is ~ 0.5 m. However, because hydrophobic compounds are generally loaded from stronger, more persistent solvents (e.g., DMSO), the hold time for loading was kept at 2 min to allow more time to rinse the sample solvent from the column before beginning the separating gradient.

The prepreparative analysis is made directly from the preparative sample; the injection volume is 5% of that which will be used in the preparative run. The prepreparative injection volume for all purifications reported here was 25 μ L, and the preparative injection volume was 0.5 mL. This ratio of prepreparative to preparative loading gave the most reliable correlation between the prepreparative MS response and the ideal MS threshold for preparative fractionation while

Table 2.

compd	supplier	CLogD ^a	mass	retention times						
				preprep	universal	Prep_25	Prep_33	Prep_40	Prep_50	Prep_65
riboflavin	Aldrich	-2.19	376.2	1.12	3.86	4.11				
triprolidine	Sigma	-0.4	278.3	1.43	4.16	4.4				
aspartame	Sigma	-1.82	294.3	1.50	4.19	4.89	3.77			
tetracaine HCl	Sigma	-0.11	264.4	1.80	4.71		4.84			
diethyl 3,3'-(phenethylimino)-dipropionate	Aldrich	1.42	321.4	1.89	4.79		5.41	4.23		
cortisone	Aldrich	1.24	360.3	1.90	5.03		5.89	4.76		
dibucaine	Sigma	0.98	343.5	2.02	5.09		6.16	4.85		
4'-fluoro-4(8-fluoro-1,3,4,5-tetrahydro-2H-pyrido(4,3-b)indol-2YL)-butyrophenoin·HCl	Acros Org.	1.26	354.4	2.03	5.03			4.82		
furosemide	Aldrich	2.91	330.3	2.10	5.34			5.71		
reserpine	Aldrich	1.53	608.4	2.12	5.22			5.68		
Crystal Violet	Sigma		371.4	2.37	5.50				4.74	
Tamoxifen	Aldrich	4.77	371.4	2.47	5.81				5.44	4.19
Clofazamine	Sigma	4.42	472.4	2.57	5.93				6.35	4.41
Disperse Red 1	Aldrich	2.09	314.4	2.65	6.55					5.54
Indomethacin	Sigma	3.10	357.4	2.72	6.51					5.59
F-DAPA		5.61		2.76	6.51					

^a LogD calculated at pH 1.5.

consuming a minimum of the sample. An acceptable correlation between prepreparative and preparative LC methods can be achieved with much smaller prepreparative loading.

Both preparative and prepreparative injection cycles included 1-mL "inside-needle" and "injection-port" rinses. No significant sample-to-sample carryover has been observed in either protocol. The total cycle time for a prepreparative analysis is ~6 min; for a preparative run, it is ~11 min.

Fraction volumes were estimated as the product of the chromatographic flow rate and the fraction collection time. Fraction recovery was determined by collecting fractions into preweighed vials, blowing down the solution to constant weight, and taking the difference between the two weights.

The sources for the standard compounds used in this work are listed in Table 2. The libraries purified here were synthesized using solution-phase parallel synthesis. Libraries 1 and 2 are capping libraries of the same proprietary core. Library 1 consists of 80 members produced by capping the core with neutral carboxylic acids; the products are neutral and very hydrophobic. Library 2 consists of 88 members generated by capping the core with Boc-protected amino acids followed by subsequent deprotection with TFA; the products are all basic with midrange hydrophobicity.

The automatic selection of the prep LC and fraction methods and creation of the prepreparative and preparative sample lists are accomplished with Sample List Generator (SLG), a custom application developed in-house using Microsoft Visual basic 6.0. The workflow for purification using SLG is as follows:

- SLG creates sample list for prepreparative analysis;
- Prepreparative LC/MS analysis is performed; report file is generated by Openlynx;
- SLG extracts RT and MS response information from report file, selects LC and MS fraction methods for prep LC/MS, generates sample list for prep LC/MS purification; and
- Prep LC/MS purification is performed.

The system administrator sets the instrument methods and files available to the user and defines the parameters and coefficients for automatic LC and fraction method selection (Figure 2a). The user interface steps the user through the available options for each phase of the sample list creation and automatic method selection (Figure 2b).

The distribution coefficients (LogD) for the standard compounds were calculated with ACD (Advanced Chemistry Development Inc.) LogD Suite, version 5.0. This software package estimates cLogD as a function of pH from estimated values of the partition coefficient, LogP, and the ionization constant, pK_a. The partition coefficient is estimated using an additive/constitutive algorithm based on separate atoms, structural fragments, and intramolecular interactions between different fragments. The ionization constant is estimated with an algorithm based on Hammett equations and known and calculated electronic constants for the various substituents.

Results

At-Column Dilution and Small-Scale Chromatography.

The essential performance characteristics of the ACD small-scale LC configuration were validated using a set of standard compounds similar to that proposed by Tang et al.;¹³ aspartame (Asp), cortisone (Crt), reserpine (Res), and Fmoc-L-Dapa-OH (F-Dapa). (The hydrophobic standard proposed by Tang, dioctyl phthalate (Dop), appeared to be a mixture of isomers when analyzed with the higher resolution methods discussed below and was replaced with F-Dapa.) This is a representative subset of a larger collection of standards (see Table 2) that provide significant structural diversity and cover a range of lypophilicity characteristic of pharmaceutically relevant compounds (cLogD values ~ -2 to 6). This set of standards will be used throughout this work. Stock solutions of reserpine and cortisone were prepared at 50 mg/mL in 1:1 DMSO/acetonitrile. A stock solution of aspartame was prepared at 30 mg/mL in 1:1 acetonitrile/methanol, and a

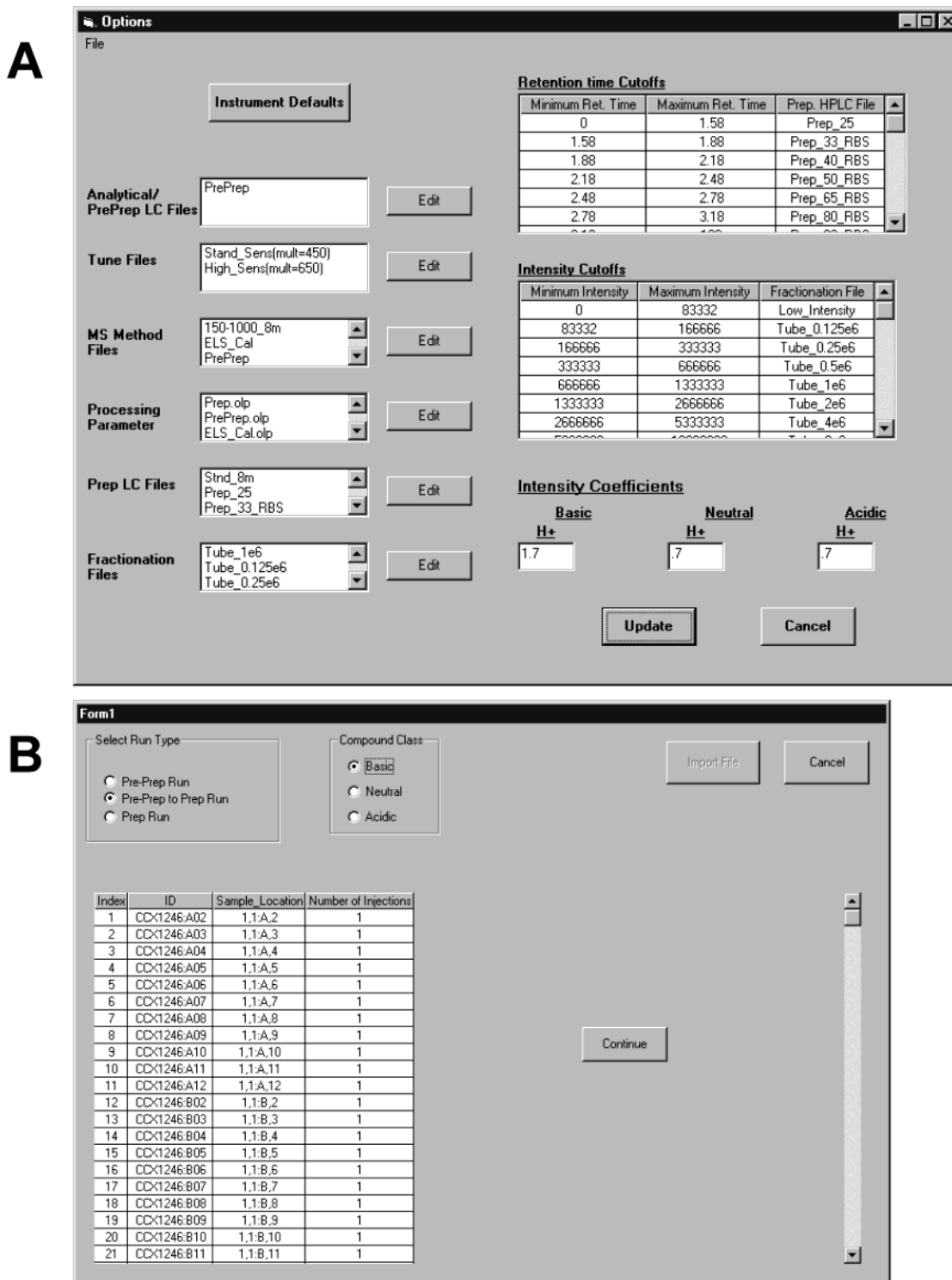

Figure 2. Sample List Generator application: (A) administrator page for setting methods and boundaries for method selection and (B) user interface for building preparative LC/MS sample list from preparative LC/MS report file.

solution of Fmoc-L-Dapa-OH was prepared at 30 mg/mL in 1:2:2 NMP/methanol/acetonitrile.

Figure 3a shows the chromatographic peak shapes from individual analyses of 20 mg of each standard using the universal prep LC method (described in Table 1) with UV detection. For all standards, the peaks are sharp and symmetric. The widths of the peaks (expressed as the full width at half-height, fwhh) depend on the mass loading (Figure 3b). Peak width increases with increasing mass loading in a uniform and approximately linear manner over the range

studied, consistent with previous reports.⁶ The intercepts (the peak width at zero mass loading) and slopes (the rate of increase in peak width with increasing mass loading) of the linear fits are compound-dependent, with slopes ranging from 0.0011 m/mg for the hydrophilic Asp to 0.0019 m/mg for the hydrophobic F-Dapa. Peak symmetry did not change appreciably over the mass loading range investigated.

Fractions were not collected during this loading study, but hypothetical fraction volumes can be estimated for these peaks as the product of the flow rate and the peak width. In

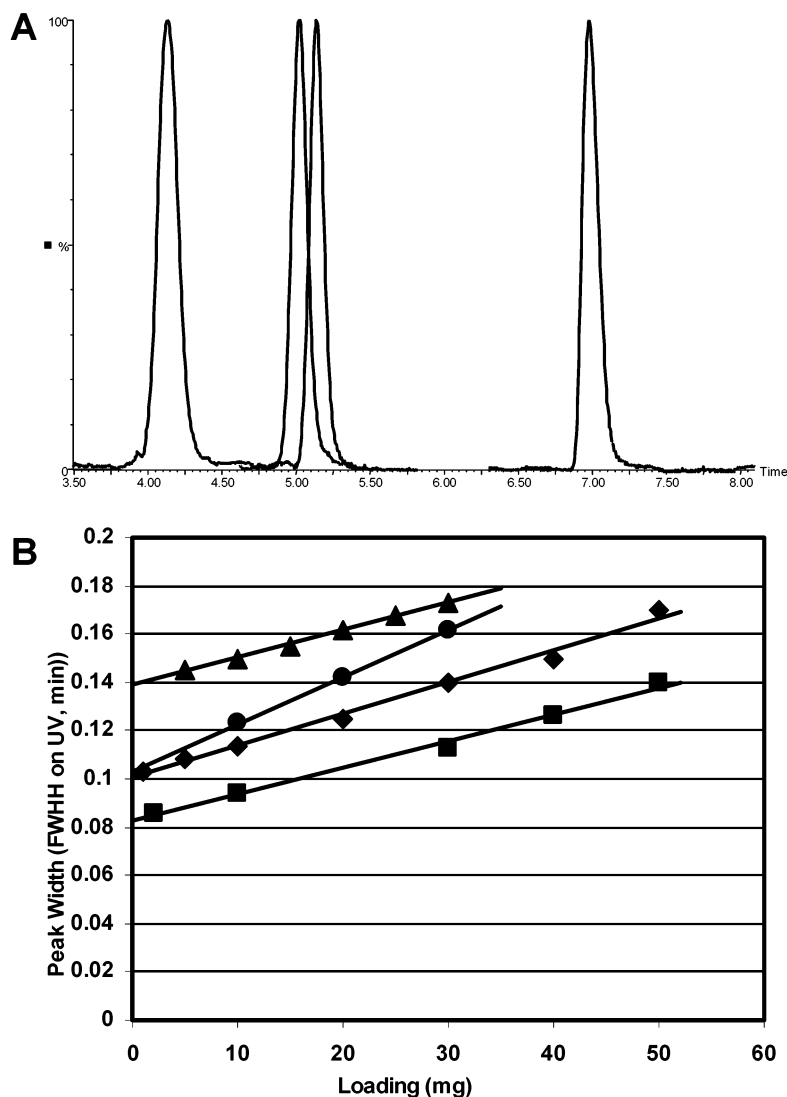

Figure 3. At-column dilution small-scale LC performance with standards: (A) peak shapes for individual 20 mg injections; (B) peak width (fwhh) vs mass loading for (▲) aspartame, (■) cortisone, (◆) reserpine, and (●) Fmoc-L-DAPA-OH.

this manner, volumes were calculated for hypothetical fractions collected between collection start and stop times defined by 10% of full height on the UV peak. Because the peak symmetry is constant over the mass loading range studied, the fraction volumes increase with increasing mass loading in the same uniform, linear manner observed for the peak width. The hypothetical fraction volumes estimated for the largest loading of Asp and F-Dapa (30 mg each) are 1.23 and 0.99 mL, respectively; the fraction volumes calculated for the largest loading of Crt and Res (50 mg each) are 0.98 and 1.13 mL, respectively. Actual fraction volumes obtained in the purification of standards and reaction products typically range from 1 to 1.3 mL (see below).

Loading 30 mg of the hydrophobic standard, F-Dapa, using the universal LC method produced a substantial increase in back pressure, from ~ 150 bar (the usual back pressure at the initial conditions) to ~ 350 bar. This is a consequence of the F-Dapa's precipitating from solution when the sample diluent is diluted with the weaker solvent (water) at the static mixing tee to the initial gradient conditions (10% strong solvent). Because the volume of the mixer-to-guard column transfer line is small, the transfer time is very short ($\ll 1$

ms), and sample precipitation occurs at the guard column, thus avoiding complete obstruction of the flow path. However, a rise in back pressure of this magnitude can still be problematic. This effect can be reduced or eliminated altogether by decreasing the dilution factor (using a higher organic composition) during the sample loading phase. For example, the "focused" prep LC method designated Prep_65 uses 26% acetonitrile during the loading phase (see Table 1); loading 30 mg of F-Dapa with this more hydrophilic method produces no discernible increase in back pressure.

Compound-Specific Focused Preparative LC Method Selection. The preparative LC method, universal preparative LC method, and focused gradient preparative LC methods are described in Table 1. The essential structure of the protocol for the compound-specific selection of the optimal preparative LC method from the preparative LC/MS data is illustrated graphically in Figure 4. The preparative retention range is divided into segments, and a focused preparative LC method is associated with each of these segments. The vertical dashed lines define the preparative RT segments and are the boundaries for selecting the associated focused preparative method for LC/MS purifica-

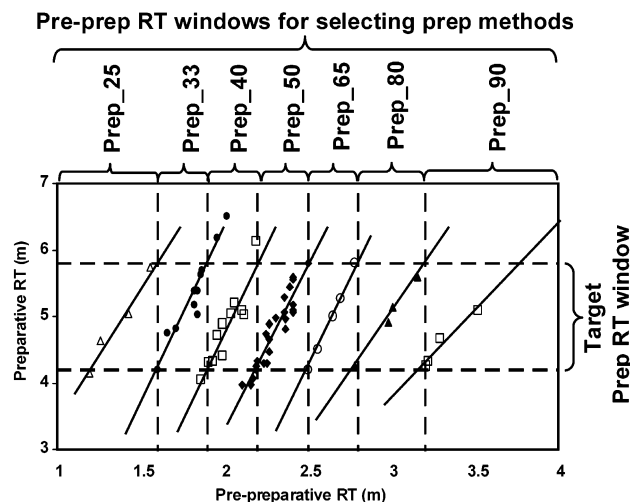

Figure 4. Graphic representation of preparative focused gradient LC method selection from prepreparative LC/MS RT data.

tion. For example, a compound with a prepreparative RT between 1.9 and 2.2 min would be purified using the focused preparative LC method designated Prep_40. The horizontal dashed lines define the “target” preparative retention time window, the center 1/3 of the preparative gradient (lower limit = 4.2 m, upper limit = 5.8 m). This is the “ideal” preparative elution range, that portion of the preparative gradient in which the greatest resolution is generally achieved (see below). The focused preparative gradients have been constructed so that a linear fit of the prepreparative to preparative RT correlation passes diagonally from the intersection of the lower prepreparative and preparative boundaries to the intersection of the upper prepreparative and preparative boundaries (represented by the solid diagonal lines in Figure 4). The specific preparative gradients required to accomplish this were developed by iteration. First, the standard compounds were used to establish preparative gradients that approximate the desired relationships. These approximate methods were then used in the purification of larger numbers of products from reaction mixtures. After each library purification, the prepreparative to preparative RT relationships were determined and assessed, the preparative gradients were adjusted as necessary, and the procedure was repeated until satisfactory approximations to the desired diagonal lines were obtained.

The preparative method represented by the most statistically significant data set in Figure 4 is Prep_50 ($N = 24$). The uncertainty in the relationship between prepreparative RT and Prep_50 RT (σ , one standard deviation in the distribution of the residuals for a nonweighted linear least squares regression) is 0.038 min for prepreparative RT and 0.186 min for preparative RT. The reproducibility of the RT measurement for a prepreparative analysis (σ determined for 23 repetitive analyses of cortisone) is 0.012 m; the reproducibility for preparative RT measurement is 0.019 m. The uncertainties in the measurement of retention time are significantly smaller than the uncertainties in the prepreparative to Prep_50 RT correlation. Thus, the majority of the uncertainty observed in the correlation is due to actual deviations in the prepreparative RT to preparative RT relationship.

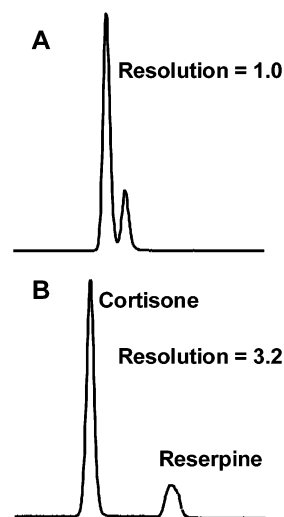

Figure 5. Prep LC/MS separation of cortisone and reserpine: (A) using universal prep LC method; (B) using focused prep LC method, Prep_40.

The reliability of a prepreparative to preparative RT correlation does depend somewhat on how well the prepreparative chromatography simulates the preparative condition. The most critical factor is matching the stationary phases of the prepreparative and preparative columns (in this case, Symmetry, C18, 5 μ M particle size were used for both). Relative column loading does not appear to be a major factor; preparative protocols utilizing sample loading between 0.5% and 5% of the preparative loading exhibited similar reliability. However, because retention time can be loading-dependent,⁶ it is important to maintain a constant ratio between prepreparative and preparative loading. Within reason, differences in column volume flow rate and gradient rate do not appear to significantly effect the prepreparative to preparative RT correlation so long as conditions remain constant. The flow rate and sample loading used in the prepreparative analysis described here were dictated primarily by requirements of the prepreparative to preparative MS response correlation (see below).

Our objective for the focused preparative LC methods and prepreparative selection process was to achieve a 3-fold improvement in chromatographic resolution relative to that attainable with the universal prep LC method of the same duration. Figure 5 shows the separation of the standards Crt and Res with the universal prep LC method and with the focused method, Prep_40. The chromatographic resolution, defined as $\Delta RT / (fwhh[pk1] + fwhh[pk2])$, obtained with the universal method is 1.0; the resolution achieved with Prep_40 is 3.2. Figure 6 shows the separation of two isomers of a synthesis product using the universal and Prep_33 methods. The isomers are not separated with the universal LC method (resolution ~ 0), whereas approximately baseline separation (resolution = 1.0) is realized with the focused method. The magnitude of the improvement in resolution obtained with the focused preparative LC methods is sample-dependent, but generally, the focused gradient methods increase the chromatographic resolution relative to the universal method by at least a factor of 3 for both standards and “real” samples.

An important consideration in the design of the ensemble of preparative LC methods and the selection protocol is the

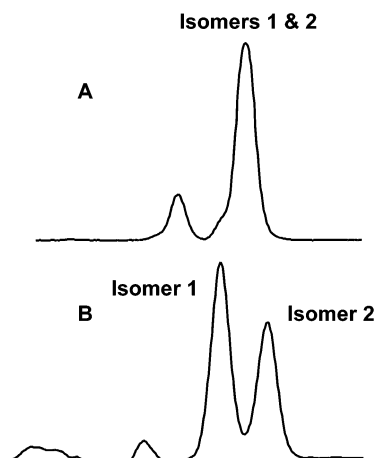

Figure 6. Prep LC/MS separation of product isomers: (A) using universal prep LC method; (B) using focused prep LC method, Prep_33.

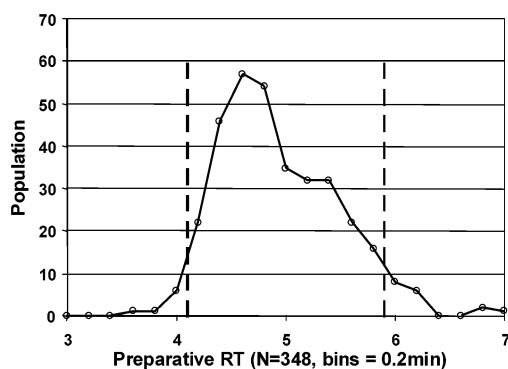

Figure 7. Distribution of prep LC/MS retention times observed using prep LC methods selected with preparative LC/MS analysis and method selection protocol.

robustness of the process; that is, the procedure must consistently select the “most appropriate” method for purification and produce a satisfactory purification if the “next-closest” method is selected because of variability in the preparative-to-preparative RT correlation. Figure 7 shows the distribution of preparative retention times obtained in the purification of 348 products from seven libraries. These libraries represent a wide range of compound hydrophobicity: ~20% of the products were purified using the most hydrophilic focused method (Prep_25), and roughly 20% were purified using the most hydrophobic method (Prep_90). The vertical dashed lines in Figure 7 represent the target preparative RT range. Approximately 93% of the preparative retention times are within the target range, indicating that the procedure had correctly selected the most appropriate method for purification. About 5% of the purifications gave retention times greater than the upper prep RT limit; roughly 85% of these were products with hydrophobicities at the extreme upper limit the protocol was designed to accommodate (based on their preparative retention times). Similarly, ~2% of the purifications exhibited retention times smaller than the lower prep RT limit; most of these were extremely hydrophilic compounds.

A satisfactory purification may still be achieved when the next closest focused method is selected if there is sufficient overlap between adjacent focused methods. Overlap is

created by limiting the target elution range to an area smaller than the actual useful elution range. Although optimum resolution is generally achieved within the target elution range (center 1/3 of gradient), “good” resolution (better than that obtainable with the universal method) is usually achieved over about the center 2/3 of the focused gradient. For example, the preparative chromatogram for a mixture of the standards Crt and Res is shown in Figure 8a. The preparative RT for Crt is 1.94 min, within the selection range for Prep_40, but only 0.04 min from the boundary with Prep_33. The uncertainty in the preparative-to-preparative RT correlation is such that there is small but finite probability that the next-best method, Prep_33, could be chosen by selection protocol. (The probability of this occurring is estimated to be ~5%.) The separations of Crt and Res with Prep_33 and with Prep_40 are shown in Figure 8b and c. The retention time for Crt using the most appropriate method, Prep_40, is ~4.8 min, within the target or ideal RT range. The RT using Prep_33 is 6.0 min, slightly outside the ideal range. Both focused preparative methods resolve the two components better than the universal method. The resolution achieved with Prep_40 is ~3.0; using the next closest method, Prep_33, the resolution is ~2.5; the resolution obtained using the universal method (Figure 5a) is ~1.0. The overlap or “effective” elution range of the focused prep LC methods appears to extend at least 0.5 min beyond the target elution range (this corresponds to deviation in preparative RT of ~0.1 min). Beyond this point, however, the quality of the chromatographic separations may be less reliable. Fewer than 1% of the 348 purifications represented by the distribution in Figure 8 exhibited retention times more than 0.5 min outside of the ideal elution range.

The validity of the preparative to preparative RT correlation is highly dependent upon the condition of both the preparative and preparative LC columns. Consequently, both are validated daily using a reference standard. If the observed RT for either analysis deviates from its historical mean by more than the 99% confidence interval (λ (99% confidence); equal to ~2.8 times σ for the measurement of RT), the LC column is replaced, and at least two standards associated with different focused preparative LC methods are analyzed. The preparative RT selection boundaries are adjusted to compensate for differences in the retention times observed with the new column if necessary. Generally, the lifetimes of both preparative and preparative columns have been on the order of several thousand samples. Column-to-column RT reproducibility has been better than the uncertainty in the RT measurement; therefore, realignment of the selection boundaries is generally not required.

Reversed-phase liquid chromatographic retention time is a function of LogD (the log of the apparent partition coefficient, logP, at a given pH value), which can be estimated from compound structure. Compound-specific prep LC methods can be selected from cLogD (calculated LogD) in a manner analogous to that described above for preparative retention time. Such an approach could offer significant savings in time and sample consumed. Figure 9a and b compares the correlation between universal prep LC retention

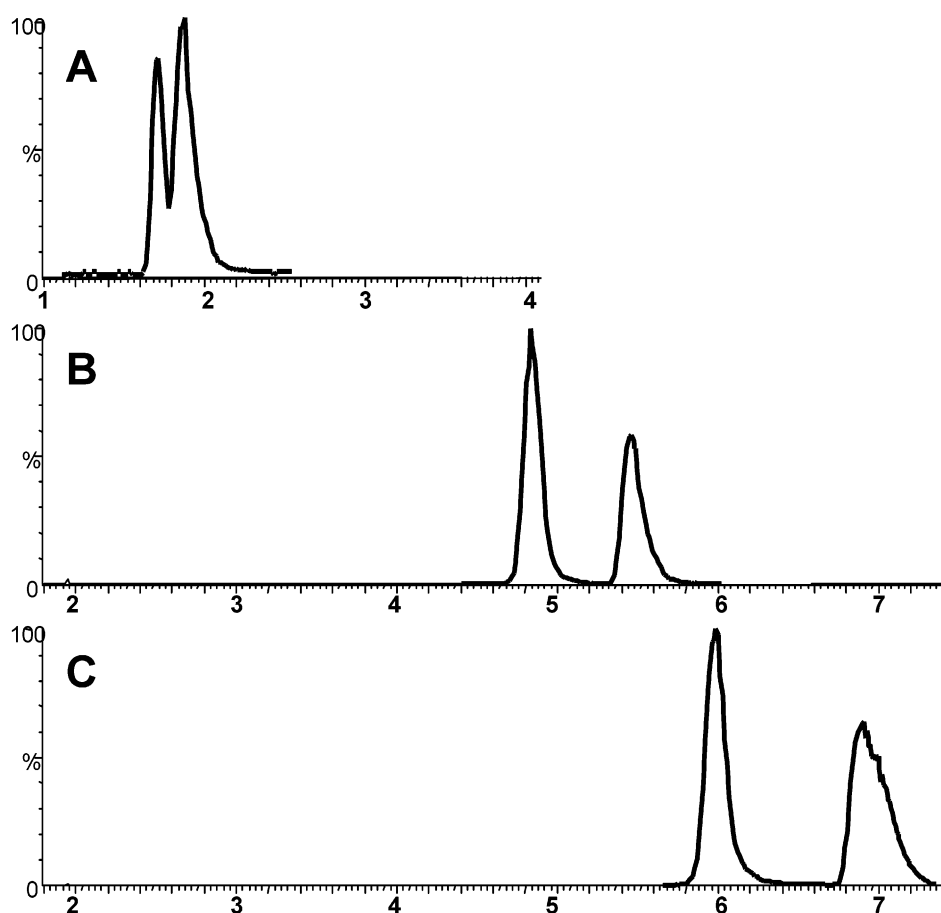

Figure 8. Overlap of adjacent focused prep LC methods: (A) preparative LC/MS analysis of cortisone/reserpine mixture; (B) prep LC/MS separation with best focused method, Prep_40; (C) prep LC/MS separation with next-closest method, Prep_33.

time and preparative retention time (for the standard compound set) with the correlation between prep RT and calculated distribution coefficient, cLogD. The correlation coefficient (square of the residuals) for the linear non-weighted least-squares fit of the preparative retention time data is 0.97, as compared to 0.74 for the cLogD fit. The poorer correlation for the fit to cLogD would translate into a substantially higher failure rate in selecting the most appropriate focused prep LC method. At the level of gradient focusing used in the ensemble of prep LC methods described above, the deviations in the cLogD correlation are, in the worst cases, large enough to result in the selection of the third-best focused prep method. In these cases, the quality of the preparative separation would be severely degraded. The rate and severity of the errors could be lessened by reducing the degree of gradient focusing; however, this would decrease the resolution of the focused methods. From these and similar analyses, we determined that the selection of focused gradient prep LC methods from cLogD cannot, at this time, provide the needed increase in chromatographic resolution and reliability.

Compound-Specific Fraction Method Selection. An analogous process is employed to select the prep LC/MS fraction method (which sets the MS threshold for fractionation). The preparative MS response is first converted to an estimated ideal MS threshold for fractionation using the known preparative to preparative MS response correlation,

then this value is used to select the most appropriate fraction method for the purification from an ensemble of fraction methods. As before, the relationship between preparative MS response and ideal MS threshold for fractionation was established by iteration. First, the relationship was estimated using standard compounds; the relationship was then refined via analyses of data obtained during the purification of several parallel synthesis libraries. For the first step, the ideal fraction was defined as that portion of the product peak delimited by 10% of full height on the leading and trailing edges of the UV chromatogram (Figure 10). The ideal MS threshold for fractionation is then equal to the preparative MS response (for the target mass) at these start and stop times. Note that the MS chromatogram virtually always exhibits significant distortion due to source overloading; consequently, the ideal MS threshold is usually greater than 10% of the full height MS response for the target mass. Loading studies with diverse reference standards established that the relationship between preparative response and ideal MS threshold is generally compound-independent (the compound-to-compound differences are less than experimental error) and is approximately constant over a fairly wide loading range (~1 to 20 mg). Consequently, the ideal threshold for preparative fractionation can be estimated simply as the product of the preparative MS response and an instrument-dependent coefficient. For one instrument,

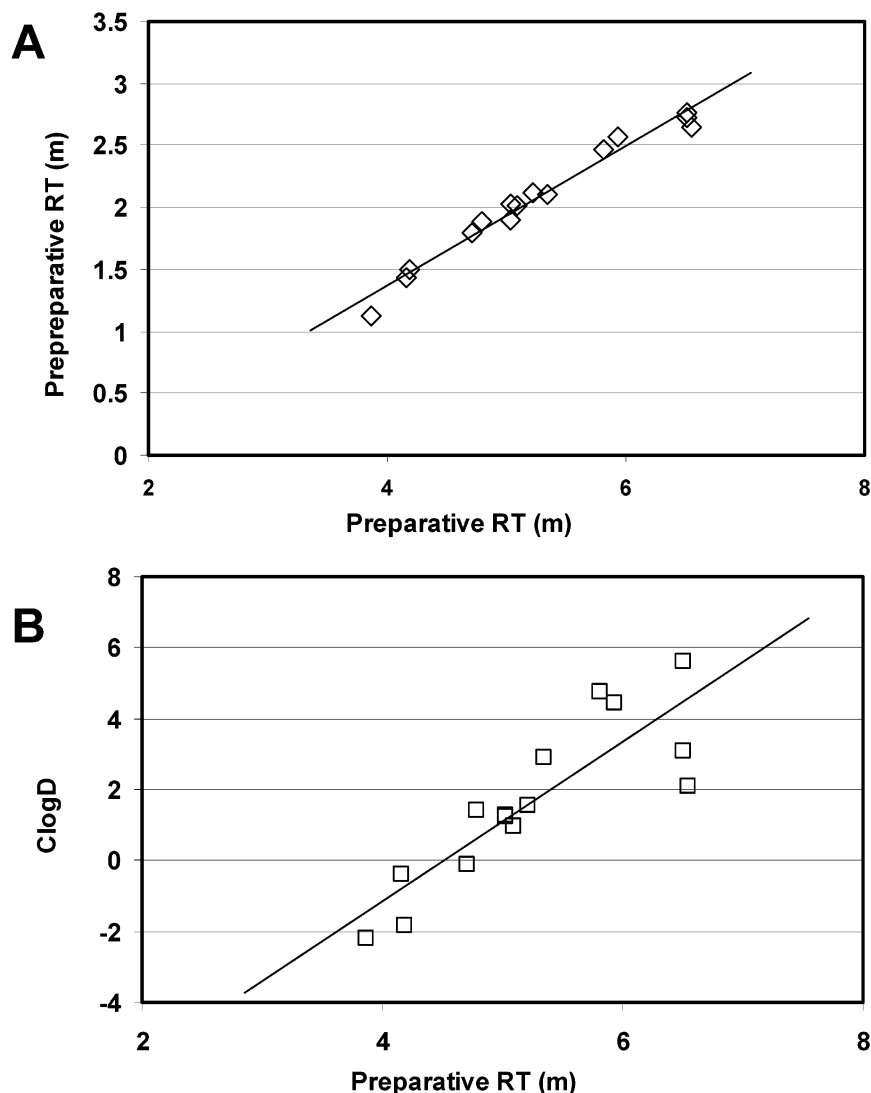

Figure 9. (A) Prepreparative RT to universal preparative RT correlation and (B) cLogD to universal preparative RT correlation.

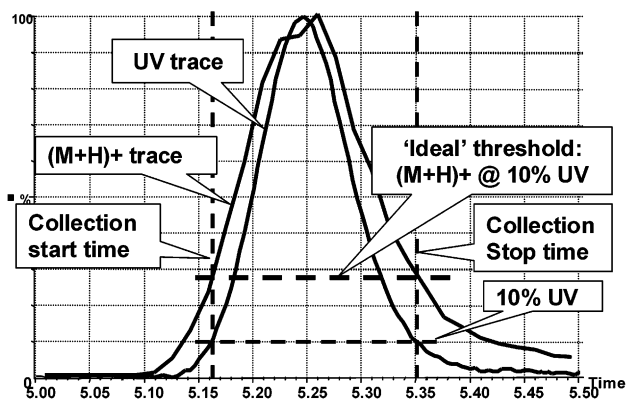

Figure 10. Definition of "ideal" prep MS threshold for fractionation.

however, the coefficients observed for basic and neutral/acidic compounds did differ by more than the experimental uncertainty. The coefficient established for basic compounds was ~ 1.7 , whereas that for neutral/acidic compounds was ~ 1.0 . This difference was deemed significant enough to justify employing different coefficients in estimating the ideal thresholds for the two groups of compounds (see Figure 2). The reason for the disparity on this instrument has not been

established; neither has it yet been determined how common such differences may be on other instruments.

The analysis outlined in Figure 10 was too cumbersome for the second phase of establishing the instrument coefficient (in which the value was refined and validated through the evaluation of MS response data for large numbers of compounds). Instead, these data were evaluated to identify a common acceptable threshold for fractionation. An acceptable threshold is $\geq 10\%$ of the maximum prep MS response for the target mass (the ideal MS threshold is generally $> 10\%$ of the full height MS response for the target mass due to source overloading; see Figure 10) and $\leq 50\%$ of the maximum prep MS response (permitting thresholds larger than 50% would lead to an increased chance of failing to trigger fractionation and losing the sample). Using this definition, refinement of the instrument coefficient was accomplished by creating a spreadsheet that included the prepreparative and preparative MS response data, the estimated ideal threshold (the product of the prepreparative response and the coefficient), and the ratio of estimated threshold to maximum preparative MS response. The value of the coefficient was then systematically varied to establish that value (or range of values) which gives the largest number

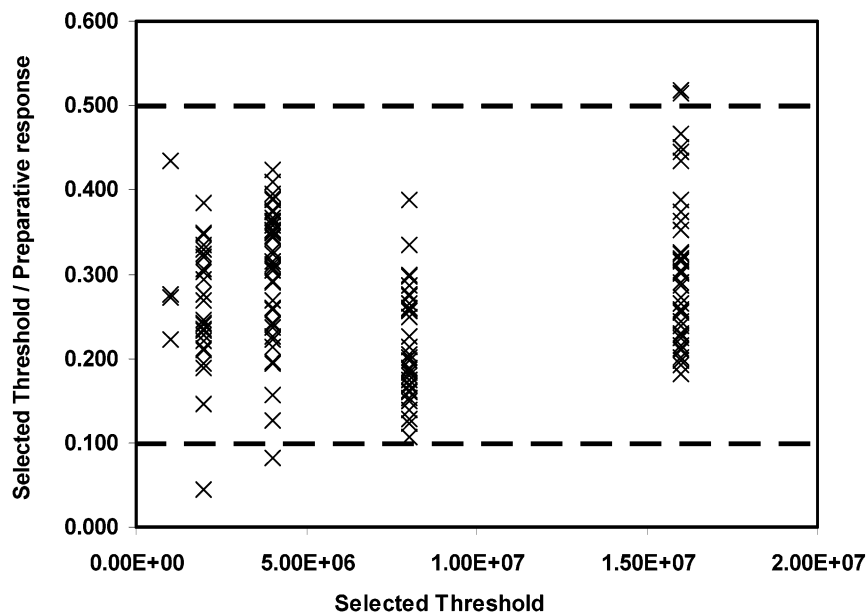

Figure 11. Selected threshold to maximum prep MS response ratios for 151 products from three libraries.

Table 3.

lower boundary (2/3 threshold)	upper boundary (4/3 threshold)	fractionation threshold	fraction method
0	1.67×10^5	1.25×10^5	Prep_0.125e6
1.67×10^5	3.33×10^5	2.50×10^5	Prep_0.25e6
3.33×10^5	6.67×10^5	5.00×10^5	Prep_0.5e6
6.67×10^5	1.33×10^6	1.00×10^6	Prep_1e6
1.33×10^6	2.67×10^6	2.00×10^6	Prep_2e6
2.67×10^6	5.33×10^6	4.00×10^6	Prep_4e6
5.33×10^6	1.07×10^7	8.00×10^6	Prep_8e6
1.07×10^7	1.00×10^{10}	$1.60E \times 10^7$	Prep_16e6

of threshold-to-response ratios within the target range (i.e., preparative MS response \times coefficient/maximum prep MS response between 10 and 50%).

The threshold estimated from the known instrument coefficient and the preparative MS response is then used to choose the most appropriate fraction method from a small ensemble of methods. The methods were created so that the MS threshold employed in the fraction method is within 33% of the estimated ideal threshold. Table 3 summarizes the fraction methods and the boundaries used to select the fraction methods from the estimated thresholds. The largest threshold utilized in this set represents $\sim 66\%$ of the preparative MS response at which the preparative to preparative correlation generally begins to break down due to severe roll-off in the response of the mass spectrometer. Employing thresholds higher than this would increase the risk of losing a sample. Figure 11 shows the selected threshold (the threshold employed by the selected fraction method) to maximum prep MS response ratios for 151 products from three libraries. Over 97% (147 of 151) of the selected thresholds were within the acceptable range (i.e., were between 10 and 50% of the maximum preparative MS response). No products were lost, and reasonable “cuts” were achieved for all products during prep LC/MS purification of these libraries.

The preparative to preparative response correlation is validated daily from the same analysis of standards used to

validate the LC column condition. If the ratio of preparative to preparative responses varies from the historical mean by more than 3σ , additional standards are analyzed to determine if the correlation coefficients need to be adjusted or the instrument requires maintenance.

Purification; Mixtures of Standards. Three binary mixtures of standard compounds were “purified” using universal LC and fraction threshold methods and employing the LC and fraction threshold methods determined with the compound specific method selection protocols described above. The results are summarized in Table 4. For all three target components, the fractional recoveries were $>95\%$, and the fraction volumes were <1.5 mL (appropriate for 2-mL 96-well plate collection). The cortisone/dibucaine pair was not well-resolved by the universal preparative LC method (Figure 12a); the purity of the collected fraction (cortisone) was 62.5%. The focused LC method does not fully resolve the mixture, either (Figure 12b), but the separation was better, and the cortisone purity improved to 93.8% with no decrease in recovery.

The very basic standard, dibucaine, exhibits considerable peak-broadening and asymmetry due to silanophilic interactions (Figure 12b). The distortion is not dependent on mass loading, and the same distortion is observed using conventional LC loading configurations. The effect is more pronounced with the shallower gradient; using the focused LC method, the observed peak width at 10% of full height (UV trace) is 0.76 m. Accomplishing “one-to-one” plate mapping with the 2-mL 96-well plate format requires limiting fraction volume to ~ 1.8 mL, corresponding to a maximum fraction width of 0.5 min. Had the dibucaine been the target product, it would have realized a recovery of $<90\%$. Minor peak-broadening is observed for many basic compounds, but is rarely severe enough to adversely affect fraction recovery (see below). Consequently, we have not attempted to identify generic chromatographic conditions that address this issue (e.g., changing stationary phase, mobile phase modifiers, etc.).

Table 4.

target component	target loading (mg)	second component	prep LC method	fraction threshold	total recovery (mg) ^a	product recovery (%) ^b	product purity (%) ^c	fraction volume (mL)
aspartame	10	riboflavin	universal	1e6	10.0	99	99.0	1.1
aspartame	10	riboflavin	Prep_25	4e6	9.9	99	100	1.2
cortisone	20	dibucaine	universal	1e6	31.3	98	62.5	0.74
cortisone	20	dibucaine	Prep_40	2e6	21.8	102	93.8	0.78
reserpine	5	Crystal Violet	universal	1e6	5.8	96	98.3	1.46
reserpine	5	Crystal Violet	Prep_50	4e6	5.9	98 ^d	99.6	1.14

^a Collected into tared vials; recovery = weight difference. ^b Recovered mass × purity/loaded mass. ^c Calculated from LC-ELS areas. ^d TFA salt of reserpine.

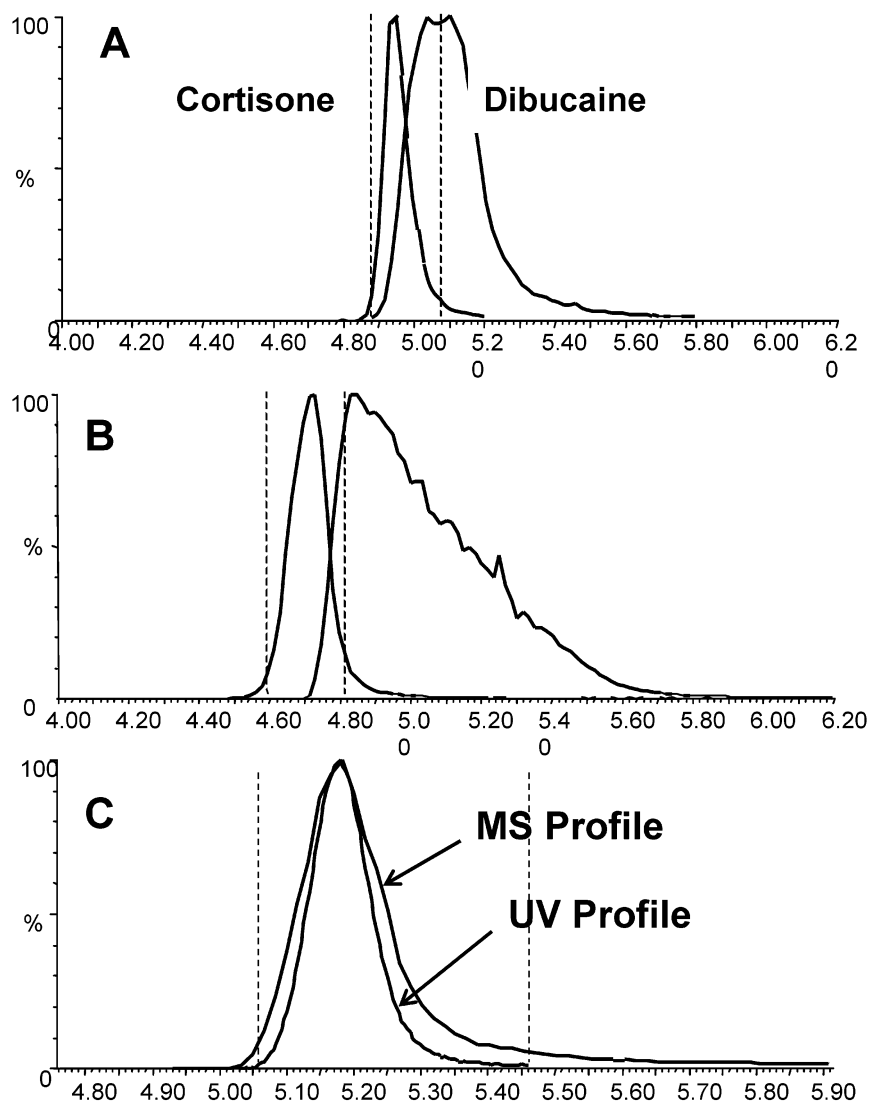

Figure 12. (A) Prep LC/MS separation of cortisone and dibucaine using (A) universal prep LC method; and (B) focused prep LC method, Prep_40; (C) UV and MS (m/z 609) profiles for reserpine.

Minor peak-tailing is observed in the UV profile of the basic standard, reserpine (Figure 12c). The distortion is magnified in the MS profile due to the nonlinear response of the mass spectrometer at the high sample concentrations encountered in prep LC/MS. Both the chromatographic and mass spectrometric distortions result in the collection of a somewhat larger than optimal fraction volume. The problem is further exacerbated in the universal purification by the use of the lower than optimal threshold for fractionation. The collected fraction volumes were 1.46 mL in the

purification using universal methods and 1.14 mL using the LC and MS methods selected with the compound specific optimization protocol. In both cases, the fraction volumes meet the criteria for full recovery into a 2-mL well. The measured purity and recovery were acceptable with both universal and selected methods (see Table 4).

Purification; Parallel Synthesis Libraries. Figure 13a and b shows representative results from two small libraries purified using LC and MS threshold methods selected with the compound-specific method optimization protocol. The

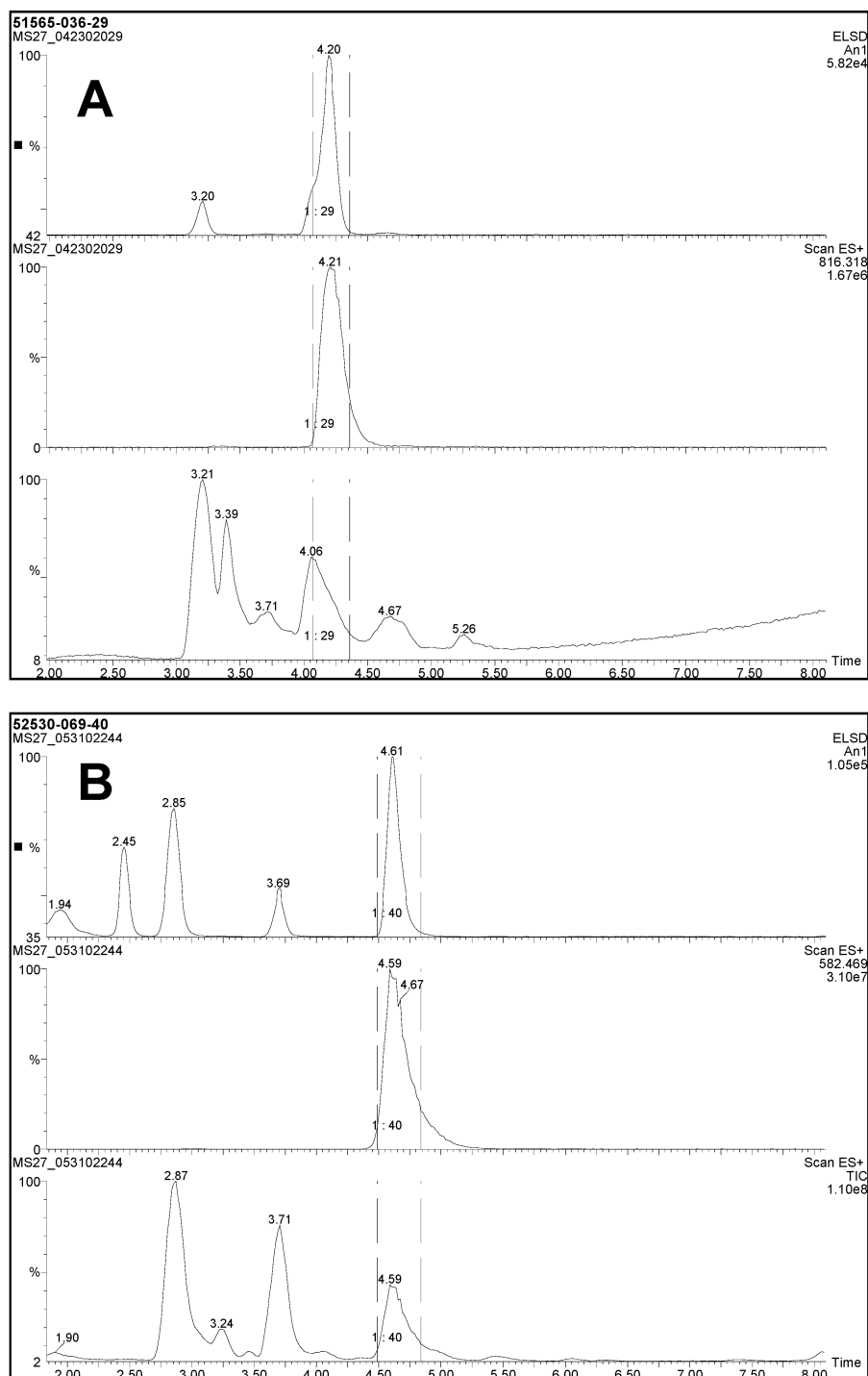

Figure 13. Representative prep LC/MS data from library purifications: (A) 80-member library of neutral compounds; average fraction volume = 1.1 mL; (B) 88-member library of basic compounds; average fraction volume = 1.4 mL.

sample loading was ~ 15 mg of crude material for both libraries, and the fractions were collected into 2-mL 96-well plates. Preparative LC/MS data (TIC, target mass chromatogram, and ELS trace) for a representative member of library 1 are shown in Figure 13a. The members of library 1 are neutral and hydrophobic. Most purifications employed the two most hydrophobic of the focused LC methods, Prep_80 and Prep_90; MS fraction thresholds ranged between 2.5×10^5 and 1.6×10^7 (factor of 64 variation due to disparity in MS response factors and chemistry yield). All 80 products were collected; all products met purity requirements; yield (estimated from ELS response) ranged from 0.5 to 10 mg;

and the average fraction volume was ~ 1.1 mL. Fraction recovery was not determined. The members of library 2 are basic with mid-range hydrophobicity. Most were purified using the focused LC methods Prep_40 and Prep_50; the fraction thresholds ranged from 1×10^6 to 1.6×10^7 (factor of 16 variation). Representative prep LC/MS data for library 2 are shown in Figure 13b. The extracted mass chromatograms for the target masses exhibit significant peak-tailing (similar to that reported above for reserpine); this resulted in the collection of slightly larger than usual fraction volumes. All 88 products were collected; all products met the purity requirements; yields ranged from about 7 to 12

mg; the average fraction volume was ~ 1.4 mL (all fraction volumes met requirements for collection into the 2-mL 96-well plate format).

Conclusions

We have described an at-column dilution small-scale preparative LC configuration optimized for purification protocols employing plate mapping and a preparative LC/MS configuration and protocol for the compound-specific optimization of preparative gradient LC methods and MS fraction threshold methods. The ACD small-scale prep LC configuration enables plate mapping of discovery-scale reactions (> 20 mg) directly into a 2-mL 96-well plate format (fraction volume < 1.5 mL). Peak shape and chromatographic behavior are good for both hydrophilic and hydrophobic compounds. This arrangement also provides numerous secondary benefits, including reduced solvent consumption; reduced waste production; reduced fraction dry down time; utilization of smaller, less expensive columns; and fewer sample diluent restrictions. The preparative LC/MS analysis and method selection protocols provide focused gradient prep LC methods and MS fraction threshold methods that meet the specific needs of each product. The focused prep LC methods improve chromatographic resolution by about a factor of 3 relative to analogous universal prep LC methods. The selected threshold for fractionation reliably effects an acceptable "center cut" of the product peak while ensuring that the product fraction is collected.

This combination of ACD small-scale preparative LC, hybrid preparative LC/MS configuration, and compound-specific prep method selection protocols greatly increases the reliability and effectiveness of prep LC/MS in the purification of parallel synthesis libraries. The time and product consumed in the preparative LC/MS analysis and method selection protocol are modest compared to the advantages realized. The methods and configurations are simple to implement and are equally suited for "open access" and "expert" applications of preparative LC/MS purification.

References and Notes

- (1) Ripka, W. C.; Baker, G.; Krakover, J. *Drug Discovery Today* **2001**, *6*, 471–477.
- (2) Jones, M. *Drug Discovery Today* **2001**, *6*, 219–220.
- (3) Kassel, D. B. *Chem. Rev.* **2001**, *101*, 255–268.
- (4) Kyranos, J. N.; Cai, H.; Wei, D.; Goetzinger, W. K. *Curr. Opin. Biotechnol.* **2001**, *12*, 105–111.
- (5) Isbell, J.; Xu, R.; Cai, Z.; Kassel, D. *J. Comb. Chem.* **2002**, *4*, 600–611.
- (6) Blom, K. *J. Comb. Chem.* **2002**, *4*, 295–301.
- (7) Blom, K.; Sparks, R.; Doughty, J.; Everlof, G.; Haque, T.; Combs, A.; ACS ProSpectives Conference on Combinatorial Chemistry, September 22–25, 2002, Leesburg, VA; American Chemical Society: Washington, DC, 2002.
- (8) Blom, K. Abstracts of Papers, 222nd National Meeting of the American Chemical Society, Chicago, IL, August 26–30, 2001, American Chemical Society: Washington, DC, 2001; p 200.
- (9) Also see: Wheat, T. *Abstracts of Papers*, Pittsburgh Conference, New Orleans, LA, March 4–9, 2001; Pittsburgh Conference: Pittsburgh, PA, 2001; p 1948. Wheat, T. *Abstracts of Papers*, 222nd National Meeting of the American Chemical Society, Chicago, IL, August 26–30, 2001; American Chemical Society: Washington, DC, 2001; p 199. Neue, U. D.; et al. *Advances in Chromatography*; Brown, P. R., Grushka, E., Eds.; Marcel Dekker: New York, 2001; pp 93–136. Thurman, E.; Mills, M. *Solid-Phase Extraction: Principles and Practice*; John Wiley & Sons, Inc.: New York, 1998. Mellor, F.; Schulte, M.; God, R.; Bindseil, K.; Gumm, H. *GIT Lab. J.* **1997**, *1*, 42–46.
- (10) See, for example Snyder, L. R.; Kirkland, J. J.; Glajch, J. L. *Practical HPLC Method Development*, 2nd ed.; John Wiley & Sons: New York, 1997; pp 622–625.
- (11) Kibbey, C. E. *Lab. Rob. Autom.* **1997**, *9*, 309–321.
- (12) Collins, N. ACS ProSpectives conference on Combinatorial Chemistry, September 22–25, 2002, Leesburg, VA; American Chemical Society: Washington, DC, 2002.
- (13) Tang, L.; Fitch, W. L.; Alexander, M. S. Dolan, J. W. *Anal. Chem.* **2000**, *72*, 5211–5218.

CC020086N